

Scientists develop a concept of a hybrid thorium reactor

29 January 2020

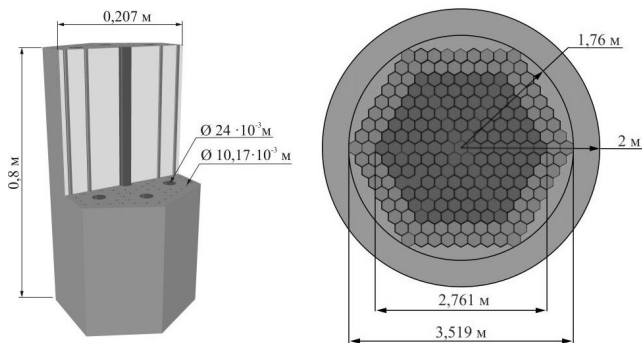

Fuel block and a cross-section of the thorium reactor core. Credit: Tomsk Polytechnic University

Russian scientists have proposed a concept of a thorium hybrid reactor in that obtains additional neutrons using high-temperature plasma held in a long magnetic trap. This project was applied in close collaboration between Tomsk Polytechnic University, All-Russian Scientific Research Institute Of Technical Physics (VNIITF), and Budker Institute of Nuclear Physics of SB RAS. The proposed thorium hybrid reactor is distinguished from today's nuclear reactors by moderate power, relatively compact size, high operational safety, and a low level of radioactive waste.

"At the initial stage, we get relatively cold [plasma](#) using special plasma guns. We retain the amount by deuterium gas injection. The injected neutral beams with particle energy of 100 keV into this plasma generate the high-energy deuterium and tritium ions and maintain the required temperature. Colliding with each other, deuterium and tritium ions are combined into a helium nucleus so high-energy neutrons are released. These neutrons can freely pass through the walls of the vacuum chamber, where the plasma is held by a magnetic field, and entering the area with nuclear fuel. After slowing down, they support the fission of heavy

nuclei, which serves as the main source of energy released in the hybrid [reactor](#)," says professor Andrei Arzhannikov, a chief researcher of Budker Institute of Nuclear Physics of SB RAS.

The main advantage of a hybrid nuclear fusion reactor is the simultaneous use of the fission reaction of heavy nuclei and synthesis of light ones. It minimizes the disadvantages of applying these nuclear reactions separately.

Also, this type of reactor has lower requirements for plasma quality and makes it possible to replace up to 95 percent of fissile uranium with thorium, which ensures the impossibility of an uncontrollable nuclear reaction. Moreover, hybrid reactors are relatively compact, have high power, and produce a small amount of radioactive waste.

"The hybrid reactor consists of two elements. The main part is the energy-generating blanket as the active zone of a nuclear reactor. It distributes nuclear fissile material that is part of nuclear fuel. Due to this, a fission chain reaction of heavy nuclei is possible. The second part is placed inside the blanket to generate neutrons that fall into the energy-generating blanket. The thermonuclear fusion reactions are generated inside this part filled with deuterium plasma, releasing the neutrons. A feature of the hybrid reactor is that the operating blanket, where the fission reactions take place, is in the subcritical state (near-critical). Operating at a constant power level, a conventional reactor is in a [critical condition](#), supported by a control and safety system," says Igor Shamanin, the head of the TPU Division of Natural Sciences and the TPU Isotope Analysis and Technology Laboratory.

According to Dr. Shamanin, the blanket was based on a concept of a multi-purpose high-temperature gas-cooled low-power reactor fueled by thorium. This concept was developed at Tomsk Polytechnic University and now it is widely represented in various scientific publications.

Currently, the project participants are considering the option to develop an experimental stand based on the TPU reactor, which will consist of a thorium fuel assembly and a [neutron](#) source.

The results of recent studies on this project are published in the journal *Plasma and Fusion Research*.

More information: Andrey V. Arzhannikov et al. Fuel Evolution in Hybrid Reactor Based on Thorium Subcritical Assembly with Open Trap as Fusion Neutron Source (Computer Simulations), *Plasma and Fusion Research* (2019). DOI: [10.1585/pfr.14.2402101](https://doi.org/10.1585/pfr.14.2402101)

Provided by Tomsk Polytechnic University

APA citation: Scientists develop a concept of a hybrid thorium reactor (2020, January 29) retrieved 3 December 2020 from <https://phys.org/news/2020-01-scientists-concept-hybrid-thorium-reactor.html>

This document is subject to copyright. Apart from any fair dealing for the purpose of private study or research, no part may be reproduced without the written permission. The content is provided for information purposes only.