

# Putting gas under pressure

12 July 2018



degree, this thermoacoustic instability hampers efficient combustion, increasing noise and pollution emissions.

Predicting and preventing thermoacoustic instabilities remains challenging for the design of a gas [turbine](#). To improve the models used, Deanna Lacoste from KAUST's Clean Combustion Research Center and her colleagues have measured the stability of gas flames at elevated pressure.

Investigation of the flame's response to acoustic forcing, uses a parameter called flame transfer function (FTF), says Francesco Di Sabatino, a Ph.D. student in Lacoste's team. The FTF is derived from experimental measurements of the [flame](#)'s response to sound waves. But these experiments are usually run at atmospheric pressure, whereas real gas turbines reach pressures of up to 30 bar.

A cut-away image of the high pressure combustion duct. Windows (far left and right) built into the apparatus enables monitoring of gas combustion. Credit: Reproduced with permission from reference 1. Figure 1b © 2018 Elsevier

Understanding gas flames' response to acoustic perturbations at high pressure should make next-generation turbines safer and more efficient.

Soldiers marching lockstep across a bridge can cause the structure to collapse if the rhythm of their step matches the bridge's natural vibration frequency. Combustion engineers must consider a similar effect when designing the gas turbines used in electricity generation and aero-engines.

Just as soldiers' feet can cause bridge sway to reach the point of destruction, a gas turbine can be damaged, or even explode, if heat and pressure fluctuations produced by the flame couple with the acoustics of the [combustion](#) chamber. At a lesser

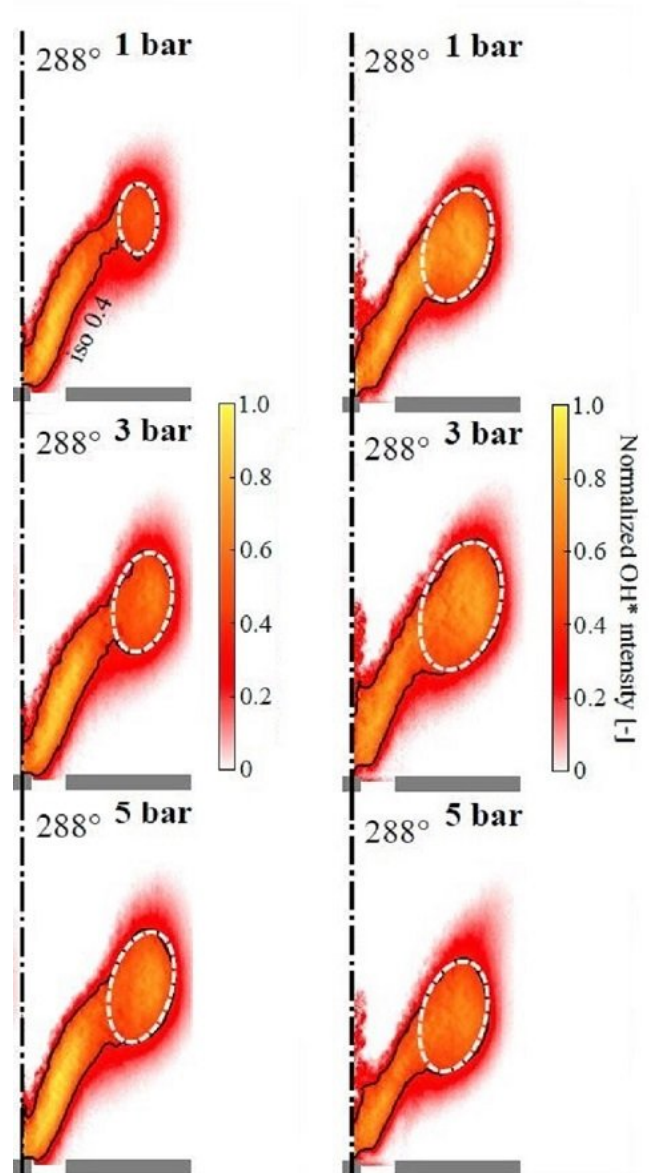
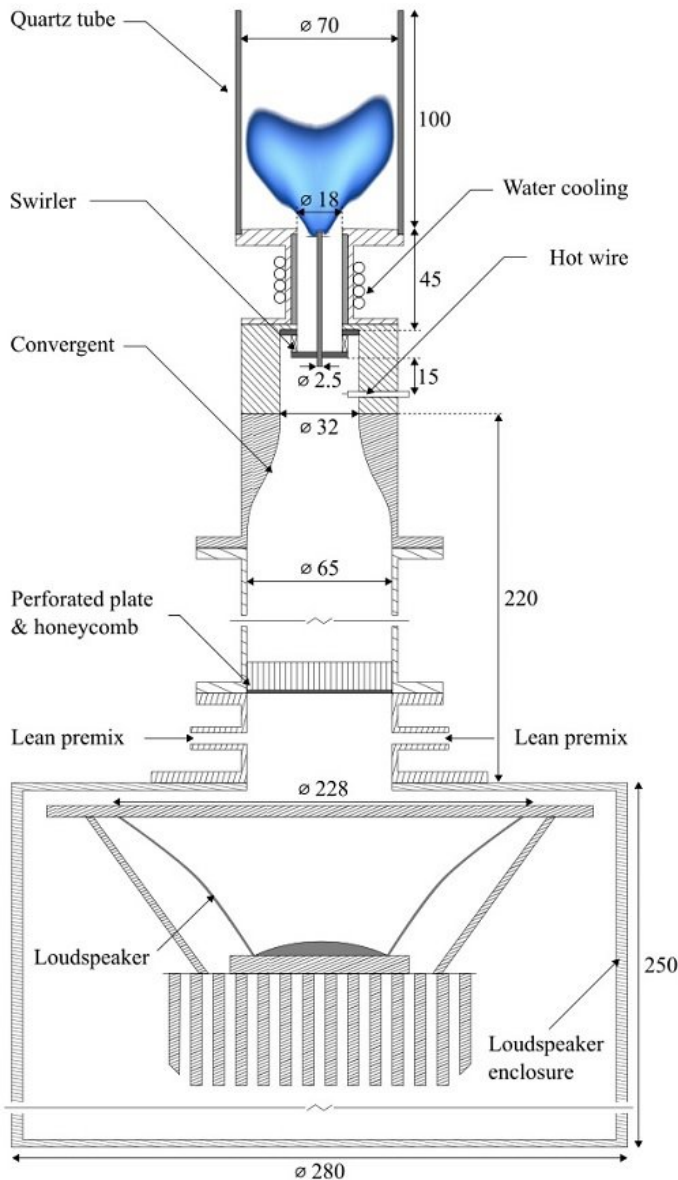

A loudspeaker generates the sound waves that test how acoustic perturbation affects the gas flame. Credit: Reproduced with permission from reference 1. Figure 1a. © 2018 Elsevier

The size of the methane flame increased with pressure when the flame was subjected to acoustic perturbation of 176 Hz (left); for propane, the size of the flame peaked at 3 bars of pressure. Credit: Reproduced with permission from reference 1. Modified from Figure 8 and 9 © 2018 Elsevier

Lacoste, Di Sabatino and their colleagues systematically investigated the effect of pressure on methane and propane gas flames. "Our experiments show the FTF at atmospheric pressure is different to the FTF at elevated pressure," says Di Sabatino. For both methane and propane gas flames, [pressure](#) had a particularly strong effect when the loudspeaker produced acoustic perturbations of 176 Hz.

**More information:** Francesco Di Sabatino et al. Effect of pressure on the transfer functions of premixed methane and propane swirl flames, *Combustion and Flame* (2018). DOI: [10.1016/j.combustflame.2018.03.011](https://doi.org/10.1016/j.combustflame.2018.03.011)

Provided by King Abdullah University of Science  
and Technology

APA citation: Putting gas under pressure (2018, July 12) retrieved 8 December 2021 from  
<https://phys.org/news/2018-07-gas-pressure.html>

*This document is subject to copyright. Apart from any fair dealing for the purpose of private study or research, no part may be reproduced without the written permission. The content is provided for information purposes only.*