

Technoeconomic model for biofuels

12 September 2013

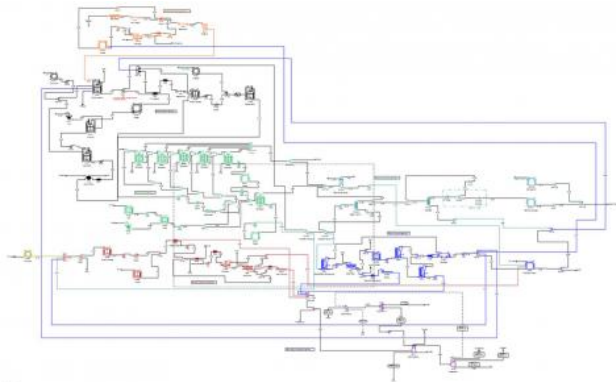

Using JBEI's technoeconomic models, researchers can provide fuel production input factors to calculate fuel, energy and greenhouse gas output and derive production costs based on different processing strategies. Credit: JBEI

Now available on-line from the Joint BioEnergy Institute (JBEI) are two new, improved versions of a technoeconomic model created in 2010 to accelerate the development of next generation biofuels that are economically competitive with petroleum-based fuels. Incorporating the latest state-of-the-art technologies relevant to bioethanol production, these new wiki-based models simulate critical factors in the biorefinery process, such as production costs and energy balances, under different scenarios. This enables researchers to concentrate their efforts on the most promising strategies for cost-efficient biorefinery operations. Both new models correspond to refinery process configuration and performance scenarios, with one reflecting the best current technologies and the other reflecting projected technological developments.

"Two aspects were improved in the new models, configuration and performance, configuration, which encompasses the chemical engineering steps in the biorefinery process, and performance, which looks at how well each of those steps accomplish their intended purpose," says Daniel

Klein-Marcuschamer, a researcher with JBEI's Deconstruction Division and one of the creators of both the original and the latest versions of the technoeconomic models. "The configuration is the same for both models, but the models differ in key process performance parameters, such as pretreatment, saccharification, and fermentation."

Like their predecessor, the new models are formulated to simulate a lignocellulosic ethanol biorefinery that uses [corn stover feedstock](#). From a comprehensive set of [fuel production](#) input factors, users can calculate the resulting ethanol, energy and [greenhouse gas](#) output, and can derive production costs, then vary the input values to test the effectiveness of different processing strategies. Murthy Konda, also with JBEI's Deconstruction Division, working with Klein-Marcuschamer, updated the original technoeconomic [model](#) on the basis of research and analytical studies published since 2010.

"Over the last few years, there has been a significant research effort globally within the field of biofuels," Konda says.

"Subsequently, there is a need to ensure that the model-based tools such as our techno-economic models are up-to-date. Addressing this need is our current release of updated models

As before, we expect these new models will continue to be useful to [biofuel](#) research community. Eventually, we will be modeling scenarios for other types of biofuels using other types of feedstocks. Already we have started modeling biorefineries based on JBEI's in-house ionic liquid pretreatment of biomass technologies."

The new models have been released in the same wiki as the original along with accompanying notes. The 2010 model is still accessible so that current users can transition to the new models as needed. First-time users are encouraged to use the new models to take advantage of the updated research results and software.

Development of the JBEI technoeconomic models has been supported by Blake Simmons, who heads JBEI's Deconstruction Division, and Harvey Blanch, JBEI's Chief Science and Technology Officer. Both hold appointments with Berkeley Lab's Physical Biosciences Division as do Konda and Klein-Marcuschamer.

The JBEI technoeconomic models for biorefinery operations is free and available for downloading [here](#)

Provided by Lawrence Berkeley National Laboratory

APA citation: Technoeconomic model for biofuels (2013, September 12) retrieved 7 December 2021 from <https://phys.org/news/2013-09-technoeconomic-biofuels.html>

This document is subject to copyright. Apart from any fair dealing for the purpose of private study or research, no part may be reproduced without the written permission. The content is provided for information purposes only.