

Chinese team develop fuel cell that can clean water as it generates electricity

19 August 2011, by Bob Yirka

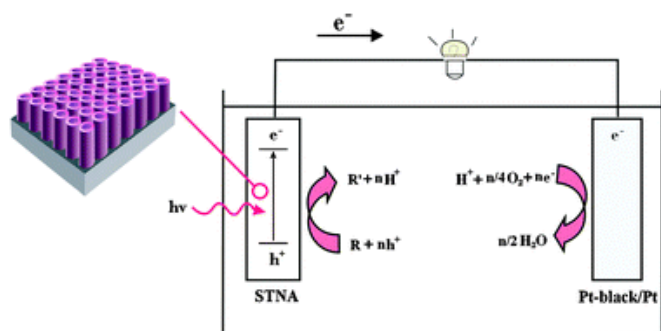

(PhysOrg.com) -- Yanbiao Liu and his colleagues from Shanghai Jiao Tong University, have succeeded in building a device capable of both cleaning wastewater and producing electricity from it. Using light as an energy source the team created a photo-catalytic fuel cell that used a titanium dioxide nanotube-array anode and a cathode based on platinum. The light energy degrades the organic material found in the wastewater and in the process generates electrons which pass through the cathode converting it into electricity. The team has published its results on *Water Science & Technology*.

Liu notes in the paper, that wastewater (the stuff that goes down the toilet when flushed) or sewage, as it's more commonly known in other countries, is a great source of environmental pollution and at the same time, is a truly important and often overlooked source of energy, which, unfortunately generally is not collected and used. It's also an expensive by-product of human existence. Every day billions of people contribute to the ever growing problem of what to do with all the human waste that is created.

In addition to [organic material](#), wastewater often contains other materials that need to be removed

in order to reuse the water for other purposes. In their lab the team tested their [fuel cell](#)'s ability to separate clear aromatics (perfumes), azo dyes, pharmaceuticals, personal care products and endocrine-disrupting compounds (birth control pill chemicals that wind up in urine) from wastewater samples and found they were able to separate them completely from the organic material thus producing clean water.

To allow the system to use visible and regular sunlight rather than UV, the team modified the electrodes with semiconductors (such as CdS) which means of course the system, if industrialized, could be used outside as an add-on perhaps to existing wastewater treatment plants. So far the team hasn't listed cost estimates for building an electrical/wastewater treatment facility with their new technology, but it's not hard to see how useful such a plant would be in areas where sewage is sometimes not treated at all, but simply dumped into rivers or streams, or worse, in the streets. In addition to helping clean up such places, the people in those areas would benefit from the electricity that would be produced in the process.

More information: A TiO₂-nanotube-array-based photocatalytic fuel cell using refractory organic compounds as substrates for electricity generation, *Chem. Commun.*, 2011, Advance Article, [DOI: 10.1039/C1CC13388H](https://doi.org/10.1039/C1CC13388H)

Abstract

A TiO₂-nanotube-array-based photocatalytic fuel cell system was established for generation of electricity from various refractory organic compounds and simultaneous wastewater treatment. The present system can respond to visible light and produce obviously enhanced cell performance when a narrow band-gap semiconductor (i.e. Cu₂O and CdS) was combined with TiO₂ nanotubes.

via [Royal Society of Chemistry](#)

© 2011 PhysOrg.com

APA citation: Chinese team develop fuel cell that can clean water as it generates electricity (2011, August 19) retrieved 21 January 2022 from <https://phys.org/news/2011-08-chinese-team-fuel-cell-electricity.html>

This document is subject to copyright. Apart from any fair dealing for the purpose of private study or research, no part may be reproduced without the written permission. The content is provided for information purposes only.