

'Invisible' Computing

7 December 2004

Computer scientists and electrical engineers from the University of California, San Diego (UCSD), have joined a consortium of mostly European scientists setting out to network together the billions of electronic devices in everyday use. The Reconfigurable Ubiquitous Networked Embedded Systems (RUNES) project aims to expand and simplify existing and future networks of devices and embedded systems. Between now and April 2007 when the project is slated to end, it will create a standardized computing infrastructure that can adjust itself to different environments and different demands placed on it.

"The goal is to create systems that link together all the 'invisible' computers around us, and make their power available for multiple new applications," said Rajesh Gupta, who holds the QUALCOMM Endowed Chair in Embedded Microsystems in UCSD's Jacobs School of Engineering. "This project will create vital new applications, from healthcare and transport systems to manufacturing and disaster recovery."

The RUNES project is supported by research funding from the European Union's Sixth Framework Programme. Major industry partners include Kodak and Ericsson. The consortium has 22 partners from six European countries, plus Australia and the United States. Only two U.S. universities are represented: UC Berkeley and UCSD. Gupta and three other scientists who are also affiliated with the California Institute for Telecommunications and Information Technology [Cal-(IT)2] will participate in the RUNES project at UCSD: Ericsson research scientist Per Johansson; assistant professor in residence Ingolf Krueger; and Ramesh Rao, director of the San Diego division of Cal-(IT)2, a partnership of UCSD and UC Irvine.

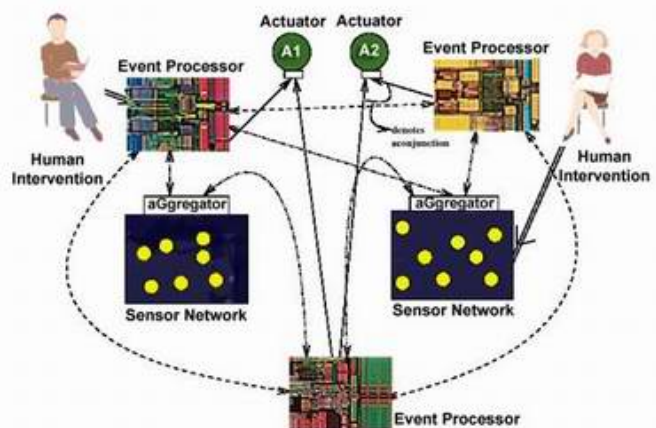

RUNES targets networks with distributed resource and location-aware computing. This graphic describes the critical network system management, and the lines portray communication among event processors, aggregators and sensor networks.

The UCSD participants are members of Cal-(IT)2's Adaptive Systems Laboratory. With funding from Ericsson and the UC Discovery Grant program, lab scientists are focusing on designing a wireless environment that is 'always on' -- regardless of location.

"Cheap and low-powered radio technologies, such as Bluetooth, and the rapid expansion of the Internet, make it practical to network these devices and systems," said Rao, who holds the QUALCOMM Endowed Chair in Telecommunications and Information Technologies in the Jacobs School. "The market for embedded systems is growing exponentially, but there are still many research challenges in networking and other areas to be addressed before all these systems can work together for the benefit of society."

Only around 2% of the billions of processors produced each year become the brains of personal computers; most go into embedded systems that

are the essence of every modern electronic device, from toys to traffic lights. They run factories and enable worldwide communication and the flow of information, products, and people. Every home in Europe and North America contains multiple embedded systems, and most people carry several around with them, from phones and watches to portable computers and music devices. The goal of RUNES is to assess and overcome barriers to exploitation of these technologies and to create standards that make it easy for programmers to develop practical and profitable applications.

"RUNES will affect how we live and do business," says EU project officer Franck Boissiere. "By joining existing devices and creating opportunities for multiple new applications, we are enabling the era of wearable computers, smart homes and a whole new generation of health monitoring."

One of the project's main outcomes will be adaptive and intelligent middleware systems that make it easy and profitable for programmers to develop new applications. As the programming that connects programs to each other, or mediates between them, middleware is critical to the networking of multiple devices. "New methods, tools, and middleware infrastructures are needed to manage the complexity in moving from mainly stand-alone hardware sensors to highly distributed, networked and reactive systems," said Cal-(IT)2's Krueger. "In these, both hardware and software sensors will cooperate to allow a vast range of new applications." Krueger's group is working on scalable design and programming models and programming platforms for networked embedded systems as they arise, for instance, in the automotive domain.

"Invisible, or pervasive, computing is already all around us, and pervasive networked computing is about to happen," said Steven Hailes, RUNES technical director and computer science lecturer at University College London. "The challenge now is to connect it all together and find standard ways to get different types of devices working across different networks to perform different functions in an 'always on' way. That is what RUNES is setting out to do."

Part of the consortium's strength lies in the broad range of technical and scientific expertise of its academic and industry partners. At launch, participants included Kodak Ltd (UK), Sira Ltd (UK), University College London (UK), University of Lancaster (UK), Ericsson AB (Sweden), Ericsson Hungary (Hungary), Industrieranlagen-Betriebsgesellschaft mbH (Germany), ConnectBlue AB (Sweden), Swedish Institute of Computer Science AB (Sweden), Virtutech AB (Sweden), LiPPERT Automationstechnik GmbH (Germany), Kungliga Tekniska Hogskolan (Sweden), Rheinisch-Westfaelische Technische Hochschule Aachen (Germany), Lund Institute of Technology (Sweden), Politecnico di Milano (Italy), University of Patras (Greece), Universita de Pisa (Italy), University of California, San Diego (USA), University of California, Berkeley (USA), University of Queensland (Australia), Victoria University (Australia), and National ICT Australia.

Source: University of California, San Diego

APA citation: 'Invisible' Computing (2004, December 7) retrieved 21 September 2019 from <https://phys.org/news/2004-12-invisible.html>

This document is subject to copyright. Apart from any fair dealing for the purpose of private study or research, no part may be reproduced without the written permission. The content is provided for information purposes only.