

# What shapes a virus's pandemic potential? SARS-CoV-2 relatives yield clues

July 29 2024, by Mallory Locklear

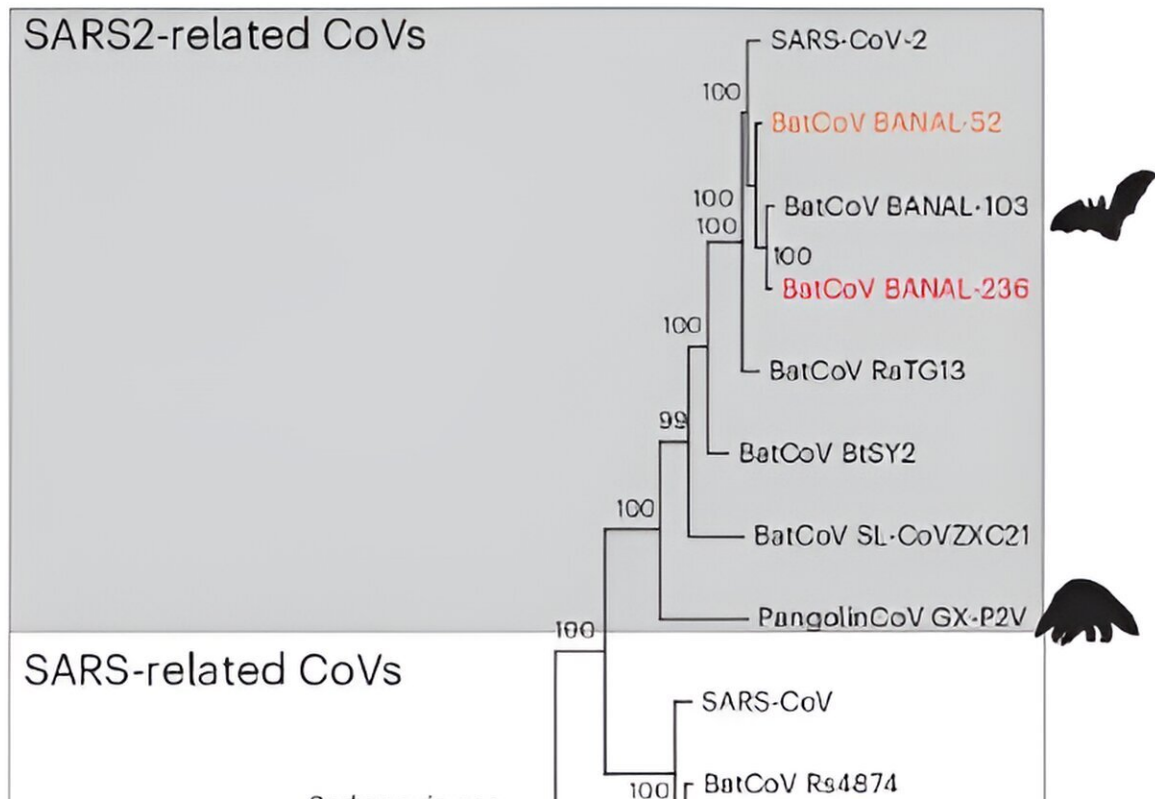

Phylogenetic tree of sarbecoviruses based on whole genome sequences. Credit: *Nature Microbiology* (2024). DOI: 10.1038/s41564-024-01765-z

Two of the closest known relatives to SARS-CoV-2—a pair of bat coronaviruses discovered by researchers in Laos—may transmit poorly

in people despite being genetically similar to the COVID-19-causing virus, a new Yale study reveals.

The findings—[published](#) July 29 in the journal *Nature Microbiology*—provide clues as to why some viruses have greater "pandemic potential" than others and how researchers might go about identifying those that do before they become widespread.

For a virus to cause a pandemic it needs to be able to transmit between people, enter human cells, evade the body's defense systems, and cause disease. SARS-CoV-2, the virus that precipitated the COVID-19 pandemic, has been able to do all of this. But it's not yet clear why it is so efficient.

"We don't know what makes a virus have pandemic potential," said Mario Peña-Hernández, a Yale Ph.D. student in the labs of Akiko Iwasaki and Craig Wilen and lead author of the study.

"These bat strains are 97% identical to SARS-CoV-2 genetically and we thought that, because they are the virus's closest known relatives, their phenotypic behavior—or the way they infect and cause disease—would be similar to SARS-CoV-2. But we found that wasn't true."

While the bat coronaviruses were able to efficiently enter some human cells and evade [defense systems](#) (often better than SARS-CoV-2 does), they did not transmit, or spread, well between hamsters and caused more mild disease in mice.

"The findings show us that we cannot tell from genomes alone what [virus strains](#) have the capacity to create a pandemic," said Peña-Hernández.

Other authors included Iwasaki, Sterling Professor of Immunobiology at Yale School of Medicine (YSM) and professor of epidemiology

(microbial diseases) at Yale School of Public Health, and Wilen, an associate professor of laboratory medicine and of immunobiology at YSM.

For the study, the researchers used copies of the two bat coronaviruses and tested how well they were able to infect lab-cultured human respiratory tract cells and rodents.

The work was done under the university's highest standard of biosafety. (Specifically, it was conducted under what is characterized as biosafety level 3+, requirements for which include restricted lab access, specialized [personal protective equipment](#) and respirators, and for experiments to be performed in biocontainment cabinets in a negative pressure facility).

The researchers found that while the two bat coronaviruses were effective at infecting cells isolated from the human bronchus—the airway that connects the trachea to the lung—they did not replicate well in cells from the nose.

"This is important to know, as most virus transmissions likely happen in the nose," said Iwasaki, a senior author of the study. "That these viruses don't replicate in the nose as well as SARS-CoV-2 could be an important indicator of why they failed to transmit in the animal models."

The body has two types of immune protection: innate immunity—a broad, general, first line of defense—and adaptive immunity, which develops over time and can protect against more specific pathogens that individuals have already been exposed to. Innate immunity is particularly important against novel viruses to which people may have no adaptive immunity.

In the study, the researchers found that the two bat coronaviruses were

able to evade certain innate immunity molecules that fight infections.

"So the viruses can infect airway cells and dodge the body's defenses, yet they still failed to transmit between animals," said Wilen, a senior author of the study. "SARS-CoV-2 could evade innate immunity and transmit, so this suggested to us that these bat coronaviruses lack something that SARS-CoV-2 has."

One thing missing from these viruses is a molecular bit known as a "furin cleavage site." In SARS-CoV-2 and some other viruses, the spike protein of the virus can be cut by an enzyme called furin in order for the virus to efficiently enter human cells.

Previous studies have found that mutated versions of SARS-CoV-2 lacking this site are less easily transmitted and cause less severe disease. In the new study, the researchers also found SARS-CoV-2 without this cleavage site didn't replicate as well in nasal cells, much like the two bat coronaviruses. In hamsters, viruses that lacked furin cleavage sites were quickly outcompeted by those that had them.

Whether a virus has this cleavage site could be one feature to look out for in the search to identify viral threats, said the researchers. However, it is likely that other viral features from this family of viruses also confer transmission or disease-causing potential.

This, they said, highlights the importance of studying these viruses in the laboratory to identify these features. For example, how well a virus replicates in nasal cells could also serve as a proxy for assessing its transmission capacity.

Overall, the findings indicate that these two bat coronaviruses pose a more modest threat to humans, although it is possible that small genetic changes in these or similar viruses may evolve and significantly enhance

pandemic risk.

However, even in the event that the viruses did cross over to humans, the researchers found that adaptive immunity against SARS-CoV-2 was protective; blood sera samples taken from individuals who were vaccinated against or previously infected by SARS-CoV-2 neutralized the viruses.

"But understanding whether viruses have the potential to transmit between humans is important," said Iwasaki, who is also a professor of dermatology at YSM, a professor of molecular, cellular, and [developmental biology](#) in Yale's Faculty of Arts and Sciences, and an investigator of the Howard Hughes Medical Institute.

"Because if we do one day find a virus that is transmissible and distinct enough from SARS-CoV-2 that we don't have immunity against it, then we could create vaccines and other strategies to combat it. We could have a head start."

**More information:** Mario A. Peña-Hernández et al, SARS-CoV-2-related bat viruses evade human intrinsic immunity but lack efficient transmission capacity, *Nature Microbiology* (2024). [DOI: 10.1038/s41564-024-01765-z](https://doi.org/10.1038/s41564-024-01765-z)

Provided by Yale University

Citation: What shapes a virus's pandemic potential? SARS-CoV-2 relatives yield clues (2024, July 29) retrieved 29 July 2024 from <https://phys.org/news/2024-07-virus-pandemic-potential-sars-cov.html>

This document is subject to copyright. Apart from any fair dealing for the purpose of private

study or research, no part may be reproduced without the written permission. The content is provided for information purposes only.