

# Long-distance quantum teleportation enabled by multiplexed quantum memories

April 19 2023

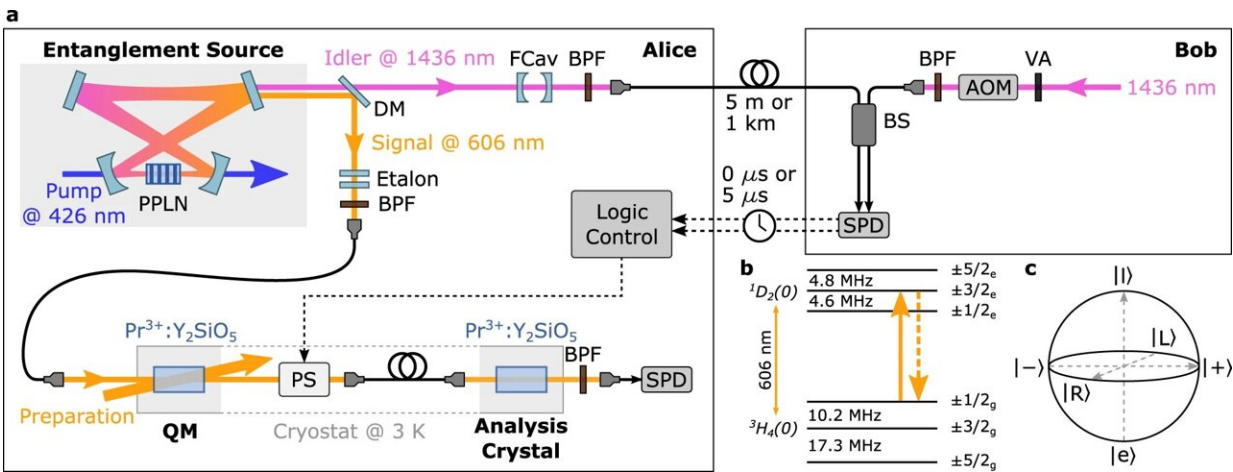

Experimental set-up. **a** Entangled photon pairs are generated at Alice. Signal photons are routed to a Pr-doped crystal, while the idler photons are sent towards Bob either through a 5 m or a 1 km long optical fiber. At Bob, arbitrary qubits at 1436 nm are produced and interfered with the idler photons in order to perform a BSM. Detection results are communicated back to Alice, where they are processed such that the feed-forward can be correctly applied. Periodically-poled lithium niobate (PPLN), dichroic mirror (DM), band pass filter (BPF), phase shifter (PS), single photon detector (SPD), filter cavity (FCav), acousto optical modulator (AOM), variable attenuator (VA). **b** Relevant level scheme of the  $\text{Pr}^{3+}:\text{Y}_2\text{SiO}_5$  crystal. **c** Bloch-sphere where all the relevant qubit states for our experiment are labeled. Credit: *Nature Communications* (2023). DOI: 10.1038/s41467-023-37518-5

Quantum teleportation is a technique allowing the transfer of quantum information between two distant quantum objects, a sender and a receiver, using a phenomenon called quantum entanglement as a resource.

The unique feature of this process is that the actual information is not transferred by sending quantum bits (qubits) through a [communication channel](#) connecting the two parties; instead, the information is destroyed at one location and appears at the other one without physically traveling between the two. This surprising property is enabled by [quantum entanglement](#), accompanied by the transmission of classical bits.

There is a deep interest in quantum teleportation nowadays within the field of quantum communications and quantum networks because it would allow the transfer of [quantum bits](#) between network nodes over very long distances, using previously shared entanglement.

This would help the integration of quantum technologies into current telecommunication networks and extend the ultra-secure communications enabled by these systems to very long distances. In addition, quantum teleportation permits the transfer of quantum information between different kinds of quantum systems, e.g., between light and matter or between different kinds of quantum nodes.

Quantum teleportation was theoretically proposed in the early 90s and experimental demonstrations were carried out by several groups around the world. While the scientific community has gained extensive experience on how to perform these experiments, there is still an open question on how to teleport information in a practical way, allowing reliable and fast quantum communication over an extended network.

It seems clear that such an infrastructure should be compatible with the current telecommunications network. In addition, the protocol of

quantum teleportation requires a final operation to be applied on the teleported qubit, conditioned on the result of the teleportation measurement (transmitted by classical bits), in order to transfer the information faithfully and at a higher rate, a feature called active feed-forward.

This means that the receiver requires a device known as a [quantum memory](#) that can store the qubit without degrading it until the final operation can be implemented. Finally, this quantum memory should be able to operate in a multiplexed fashion to maximize the speed of teleporting information when the sender and the receiver are far away. To date, no implementation had incorporated these three requirements in the same demonstration.

In a recent study published in *Nature Communications*, ICFO researchers Dario Lago-Rivera, Jelena V. Rakonjac, Samuele Grandi, led by ICREA Prof. at ICFO Hugues de Riedmatten have reported achieving long distance teleportation of quantum information from a [photon](#) to a solid-state qubit, a photon stored in a multiplexed quantum memory.

The technique involved the use of an active feed-forward scheme, which, together with the multimodality of the memory, has allowed maximization of the teleportation rate. The proposed architecture was compatible with the telecommunications channels, and thus enabling future integration and scalability for long-distance quantum communication.

## **How to achieve quantum teleportation**

The team built two experimental setups, that in the jargon of the community are usually called Alice and Bob. The two setups were connected by a 1km optical fiber spun up in a spool, to emulate a physical distance between the parties.

Three photons were involved in the experiment. In the first setup, Alice, the team used a special crystal to create two entangled photons: the first photon at 606 nm, called signal photon, and the second photon called idler photon, compatible with the telecommunications infrastructure.

Once created, "we kept the first 606 nm photon at Alice and stored it in a multiplexed solid-state quantum memory, holding it in the memory for future processing. At the same time, we took the telecom photon created at Alice and sent it through the 1km of [optical fiber](#) to reach the second experimental setup, called Bob," Dario Lago recalls.

In this second setup, Bob, the scientists had another crystal where they created a third photon, where they had encoded the quantum bit they wanted to teleport. Once the third photon was created, the second photon had arrived to Bob from Alice, and this is where the core of the teleportation experiment takes place.

## **Teleporting information over 1km**

The second and third photons interfered with each other through what is known as a Bell State measurement (BSM). The effect of this measurement was to mix the state of the second and third photon. Thanks to the fact that the first and second photons were entangled to begin with, i.e. their joint state was highly correlated, the result of the BSM was that of transferring the information encoded in the third photon to the first one, stored by Alice in the quantum memory, 1 km away.

As Dario Lago and Jelena Rakonjac mention, "we are capable of transferring information between two photons that were never in contact before, but connected through a third photon that was indeed entangled with the first. The uniqueness of this experiment lies in the fact that we employed a multiplexed quantum memory capable of storing the first

photon for long enough such that by the time Alice found out that the interaction had happened, we were still able to process the teleported information as the protocol requires."

This processing that Dario and Jelena mention was the active feed-forward technique mentioned earlier. Depending on the outcome of the BSM, a phase-shift was applied to the first photon after storage in the memory. In this way, the same state would always be encoded in the first photon. Without this, half of the teleportation events would have to be discarded.

Moreover, the multimodality of the quantum memory allowed them to increase the teleportation rate beyond the limits imposed by the 1 km separation between them without degrading the quality of the teleported qubit. Overall, this resulted in a teleportation rate three times higher than for a single-mode quantum memory, only limited by the speed of the classical hardware.

## **Scalability and integration**

The experiment carried out by this group in 2021, where they achieved for the first time entanglement of two multimode quantum memories separated by 10 meters and heralded by a photon at the telecommunication wavelength, has been the precursor of this experiment.

As Hugues de Riedmatten emphasizes, "Quantum teleportation will be crucial for enabling high-quality long-distance communication for the future quantum internet. Our goal is to implement [quantum teleportation](#) in more and more complex networks, with previously distributed entanglement. The solid-state and multiplexed nature of our quantum nodes as well as their compatibility with the telecom network make them a promising approach to deploy the technology over long distance in the

installed fiber network."

Further improvements are already being planned. On the one hand, the team is focused on developing and improving the technology in order to extend the setup to much longer distances while maintaining the efficiency and rates. On the other hand, they also aim at studying and using this technique in the transfer of information between different types of quantum nodes, for a future quantum Internet that will be able to distribute and process quantum information between remote parties.

**More information:** Dario Lago-Rivera et al, Long distance multiplexed quantum teleportation from a telecom photon to a solid-state qubit, *Nature Communications* (2023). [DOI: 10.1038/s41467-023-37518-5](https://doi.org/10.1038/s41467-023-37518-5)

Provided by ICFO

Citation: Long-distance quantum teleportation enabled by multiplexed quantum memories (2023, April 19) retrieved 17 July 2024 from <https://phys.org/news/2023-04-long-distance-quantum-teleportation-enabled-multiplexed.html>

<p>This document is subject to copyright. Apart from any fair dealing for the purpose of private study or research, no part may be reproduced without the written permission. The content is provided for information purposes only.</p>
--