

Open sourced control hardware for quantum computers

February 24 2022, by Monica Hernandez, Joe Chew

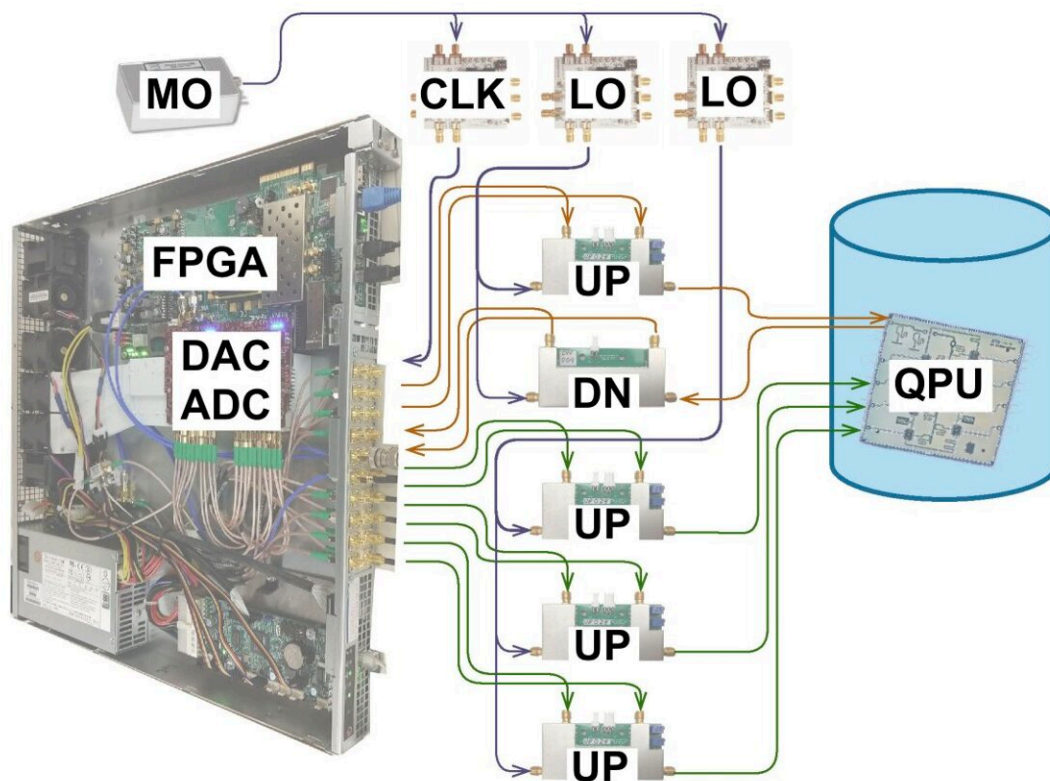

Diagram of QubiC prototype showing room-temperature electronics hardware.
Credit: Gang Huang and Yilun/Berkeley Lab

The Advanced Quantum Testbed (AQT) at Lawrence Berkeley National

Laboratory (Berkeley Lab) has [open sourced](#) a new electronics control and measurement system for superconducting quantum processors, making the engineering solutions for the emerging hardware more accessible. Superconducting circuits are one of the leading quantum computing technologies seeking to solve complex problems beyond the reach of classical computers.

AQT's superconducting qubit control system—QubiC for short—is customizable and modular. QubiC's performance data was published in [IEEE Transactions on Quantum Engineering](#). Researchers Gang Huang and Yilun Xu from Berkeley Lab's Accelerator Technology and Applied Physics Division (ATAP) led the AQT QubiC design, leveraging a robust technological legacy in research and development for particle accelerators. AQT is funded by the Advanced Scientific Computing Research (ASCR) program in the U.S. Department of Energy Office of Science.

The need for more affordable qubit control

Quantum information processors require expensive electronic controls that can manipulate qubits with precision. However, it is both a theoretical and experimental challenge to develop the control hardware that maximizes quantum computers' performance. Furthermore, current coherence times are short-lived, and most commercially available electronic equipment is designed as general-purpose for non-[quantum systems](#). The cost, size, and complexity of control and measurement hardware increase with a growing number of qubits. This presents a significant roadblock for startups and junior academic research groups worldwide.

AQT's researchers at Berkeley Lab are tackling these control challenges by [designing modular control hardware](#) for current and future superconducting processors and open sourcing the system's full-stack

code, so that it can be accessed, improved, and leveraged by the broader quantum information science community.

"Newer control electronics systems are not tailored for quantum control systems," explained Huang. "So quantum researchers need to make the control system bigger by purchasing more instruments as the processors become more complex. But the cost for control hardware should not be linear or exponential, and that's where we try to come in. By building this as a more accessible and affordable system from the ground up, we really know what happens underneath for further integrations and to try to scale the design."

QubiC integrates an FPGA (field-programmable gate array) RF (radio frequency) system, which modulates the signals at room temperature to manipulate and measure the superconducting qubits cooled down to cryogenic temperatures. AQT's cryogenic dilution fridge "[Blizzard](#)" reaches very low temperatures, close to absolute zero.



Researchers Gang Huang and Yilun Xu led the QubiC design leveraging robust research and development for particle accelerators at Berkeley Lab. Credit: Christian Jünger/Berkeley Lab

QubiC's Python-based software and firmware implement the control and measurement protocols to characterize and [benchmark](#) the quantum chips, optimize one- and two-qubit gate algorithms, and [mitigate errors](#). Experimental results have demonstrated that QubiC executes quantum algorithms with promising synchronicity and speed, delivering results similar to commercially available systems at less cost.

"We're working on providing a more modular and affordable hardware

control solution that performs equal to or slightly better with the added benefits," emphasized Huang. "But we cannot do everything by ourselves, so by open sourcing the code, we can find a community willing to support, contribute, and develop."

QubiC is compatible with commercial and custom-designed electronics. As a result, testbed users from a variety of national laboratories, startups, and companies have shown strong interest to deploy their projects using QubiC's customizable interface.

Xu explained: "Open sourcing the full stack of the QubiC system benefits the community because more people can contribute, customize, and improve it. And as an early career researcher involved in its design from the start, I have learned to integrate different disciplines from engineering to physics to experiments."

Leveraging the legacy of particle accelerators

The research and development of AQT's control hardware comes from a seemingly unlikely source, but that leverages Berkeley Lab's origins and 91-year history: particle accelerators. Across their many sizes and purposes—ranging from compact medical treatment machines to extensive research facilities like the Large Hadron Collider—accelerators speed up charged particles and funnel them into a controlled beam to explore matter and energy.

As particle accelerators grow more powerful, the need for state-of-the-art instrumentation and control systems increases. It's critical to precisely stabilize particle beams and the sophisticated equipment that produces them. The resulting technology and know-how can benefit many other fields, such as quantum computing.

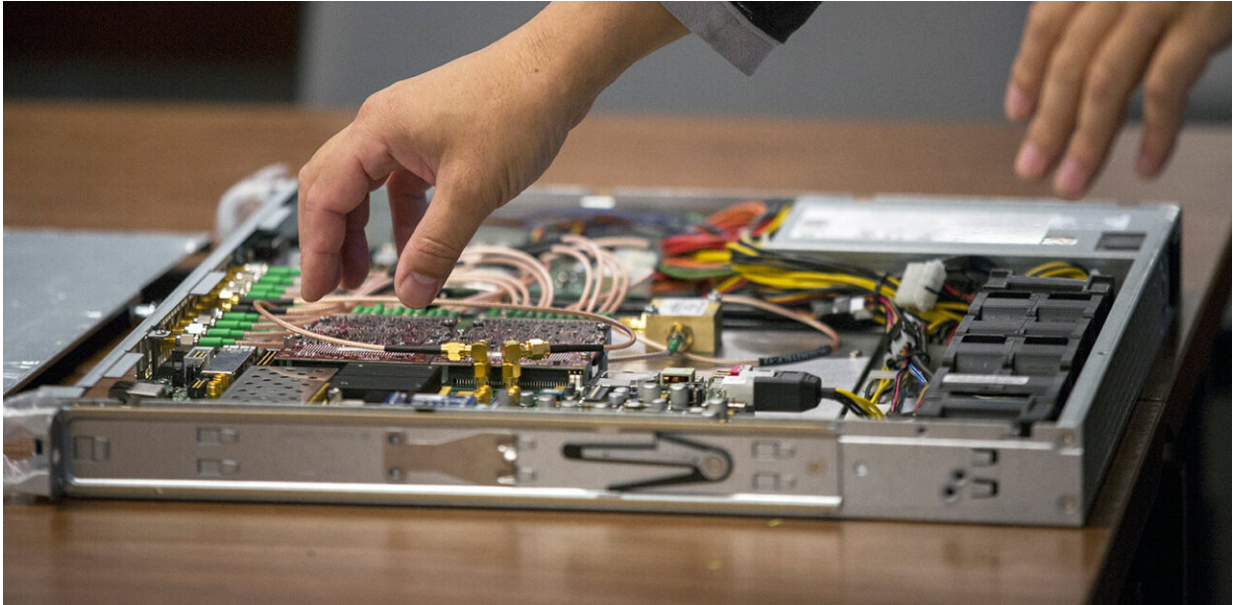

Researchers designed and open sourced a modular field-programmable gate array (FPGA)-based electronics control system called QubiC for superconducting quantum information processors. Credit: Berkeley Lab

Huang and Xu are members of the Berkeley Accelerator Controls and Instrumentation (BACI) Program, where expertise in these control systems is a common resource crucial to the varied efforts of the ATAP Division. BACI, supported by the General Accelerator R&D program in the DOE Office of High Energy Physics, has a decades-long history of developing precision control and feedback systems for particle accelerator projects. "I am very happy to see that previous investment for accelerator controls now can be further developed and used for qubits controls," said BACI Program Head Derun Li.

"Particle accelerators are a vital component of Berkeley Lab's scientific endeavors, so the work with advanced FPGA-based RF control technology and engineering for particle beams helped us streamline the customization for quantum hardware," added Huang. "AQT researchers

and testbed users are able to take advantage of the open source toolbox and gain a deeper understanding of flexible control hardware platforms that are both cost-effective and scalable."

ATAP Director Cameron Geddes described the QubiC design for AQT's superconducting processors as "classic examples of how capabilities developed for one area can benefit others in the team-science tradition of Berkeley Lab."

Open access testbed

Extensible quantum computers will require significant modifications to current tools and standard techniques, which is why AQT researchers have pioneered the open sourced control hardware used in the Berkeley Lab quantum computing testbed program that is inspired by technology transfer of [particle accelerators](#).

By providing AQT users full stack access to QubiC and its infrastructure, the broader community has access to state-of-the-art superconducting quantum processors and co-participates in their evolution, potentially making QubiC compatible with other quantum computing technologies as well.

More information: Yilun Xu et al, QubiC: An Open-Source FPGA-Based Control and Measurement System for Superconducting Quantum Information Processors, *IEEE Transactions on Quantum Engineering* (2021). [DOI: 10.1109/TQE.2021.3116540](https://doi.org/10.1109/TQE.2021.3116540)

Provided by Lawrence Berkeley National Laboratory

Citation: Open sourced control hardware for quantum computers (2022, February 24) retrieved 28 April 2024 from <https://phys.org/news/2022-02-sourced-hardware-quantum.html>

This document is subject to copyright. Apart from any fair dealing for the purpose of private study or research, no part may be reproduced without the written permission. The content is provided for information purposes only.