

# Combining two approaches to advance quantum computing

July 26 2021

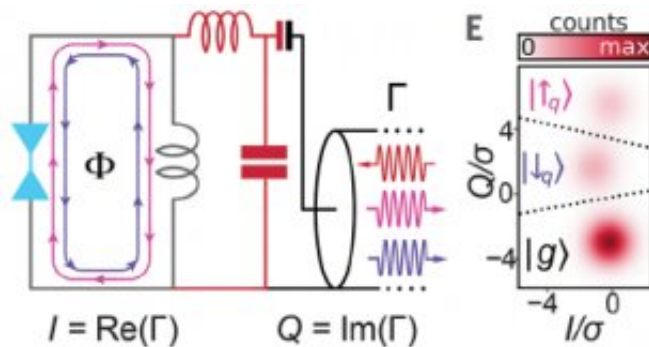

Credit: Yale School of Engineering and Applied Science

Quantum computers hold the potential to out-perform all conventional computing systems. Two promising physical implementations for the storage and manipulation of quantum information are the electromagnetic modes of superconducting circuits and the spins of small numbers of electrons trapped in semiconductor quantum dots.

A team of researchers led by the lab of Michel Devoret, the Frederick W. Beinecke Professor of Applied Physics, experimentally demonstrated a new quantum bit ("qubit") that fuses these two platforms, with the potential to take on the beneficial aspects of both. The results are published today in *Science*.

The qubit consists of the spin of an individual superconducting

quasiparticle trapped in a Josephson junction. Due to a [spin-orbit](#) coupling in the junction, the supercurrent flowing through the junction depends on the quasiparticle spin state.

"We were able to show how to harness this spin-dependent supercurrent to achieve both spin detection and coherent spin manipulation," said Max Hays, a Ph.D. student in Devoret's lab, and lead author of the study.

This work also represents a significant advancement to our understanding and control of Andreev levels. Andreev levels are microscopic, electronic states that exist in all Josephson junctions; they are the microscopic origin of the famous Josephson effect, in which a current flows without any voltage. In superconductor-semiconductor heterostructures such as the nanowire junctions investigated in this experiment, Andreev levels are the parent states of Majorana modes (special states in which the two "halves" of an electron are pulled apart). Therefore, this experiment is also important for efforts to perform Majorana-based topological information processing.

**More information:** M. Hays et al, Coherent manipulation of an Andreev spin qubit, *Science* (2021). [DOI: 10.1126/science.abf0345](https://doi.org/10.1126/science.abf0345)

Provided by Yale University

Citation: Combining two approaches to advance quantum computing (2021, July 26) retrieved 8 May 2024 from <https://phys.org/news/2021-07-combining-approaches-advance-quantum.html>

This document is subject to copyright. Apart from any fair dealing for the purpose of private study or research, no part may be reproduced without the written permission. The content is provided for information purposes only.