

Students make neutrons dance beneath UC Berkeley campus

September 11 2019

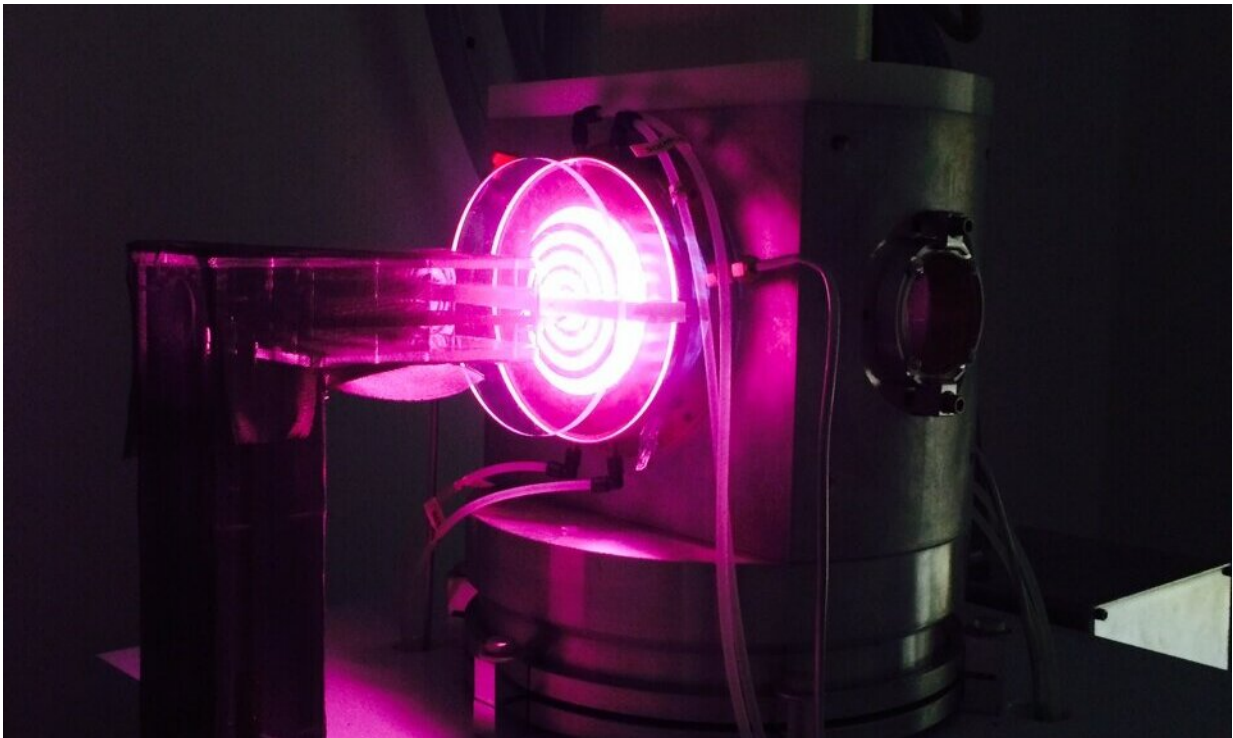

In the high flux neutron generator, UC Berkeley researchers heat up deuterium atoms in a vacuum chamber to 50,000 degrees Celsius to obtain an ionized plasma (pink glow), then accelerate the ions until they collide and fuse with other deuterium atoms implanted in the titanium cathode, releasing neutrons in the process. The spiral coil is the water-cooled radio-frequency antenna that heats the plasma, viewed through a quartz window into the vacuum chamber. Credit: Cory Waltz, LLNL

In an underground vault enclosed by six-foot concrete walls and accessed by a rolling, 25-ton concrete-and-steel door, University of California, Berkeley, students are making neutrons dance to a new tune: one better suited to producing isotopes required for geological dating, police forensics, hospital diagnosis and treatment.

Dating and forensics rely on a spray of neutrons to convert atoms to radioactive isotopes, which betray the chemical composition of a substance, helping to trace a gun or reveal the age of a rock, for example. Hospitals use isotopes produced by neutron irradiation to kill tumors or pinpoint diseases like cancer in the body.

For these applications, however, only nuclear reactors can produce a strong enough spray of neutrons, and there are only two such reactors west of the Mississippi.

As an alternative, a team including UC Berkeley students has built a tabletop neutron source that would be relatively inexpensive to reproduce and eventually portable and also able to produce a narrower range of neutron energies, minimizing the production of unwanted radioactive byproducts.

"Any hospital in the country could have this thing, they could build it for a few hundred thousand dollars to make local, very short-lived medical isotopes—you could just run them up the elevator to the patient," said Karl van Bibber, a UC Berkeley professor of nuclear engineering who oversees the students perfecting the device. "It has application in geochronology, neutron activation analysis for law enforcement agencies—when the FBI wants to determine the provenance of a sample as evidence, for example—neutron radiography, to look for cracks in aircraft parts. This is very compact, the size of a little convection oven; I think it's great, we are excited about this."

UC Berkeley researchers have now demonstrated that the high flux neutron generator (HFNG) can produce "boutique" neutrons—neutrons within a very narrow range of energies—that can be used to accurately date fine-grained rocks nearly impossible to date by other radioisotope techniques. The study will be published this week in the journal *Science Advances*.

"This will expand the capability of dating fine-grained materials, like clay minerals associated with ore deposits, including gold, or lava flows," said Paul Renne, a UC Berkeley professor-in-residence in the Department of Earth and Planetary Science and director of the Berkeley Geochronology Center. "This device might also let us look at the most primitive objects in our solar system—calcium/aluminum-rich inclusions found in certain types of meteorites—which are also very fine-grained."

As they report in the new paper, the researchers used the neutron generator to determine the age of fine-grained lava from the 79 A.D. eruption of Vesuvius, which buried the Roman city of Pompeii. The date they calculated was as precise as the answer given by an exhaustive study in 1997 using state-of-the-art argon-argon dating of samples irradiated at a nuclear reactor.

"It's making it possible to do things that were not possible otherwise," Renne said.

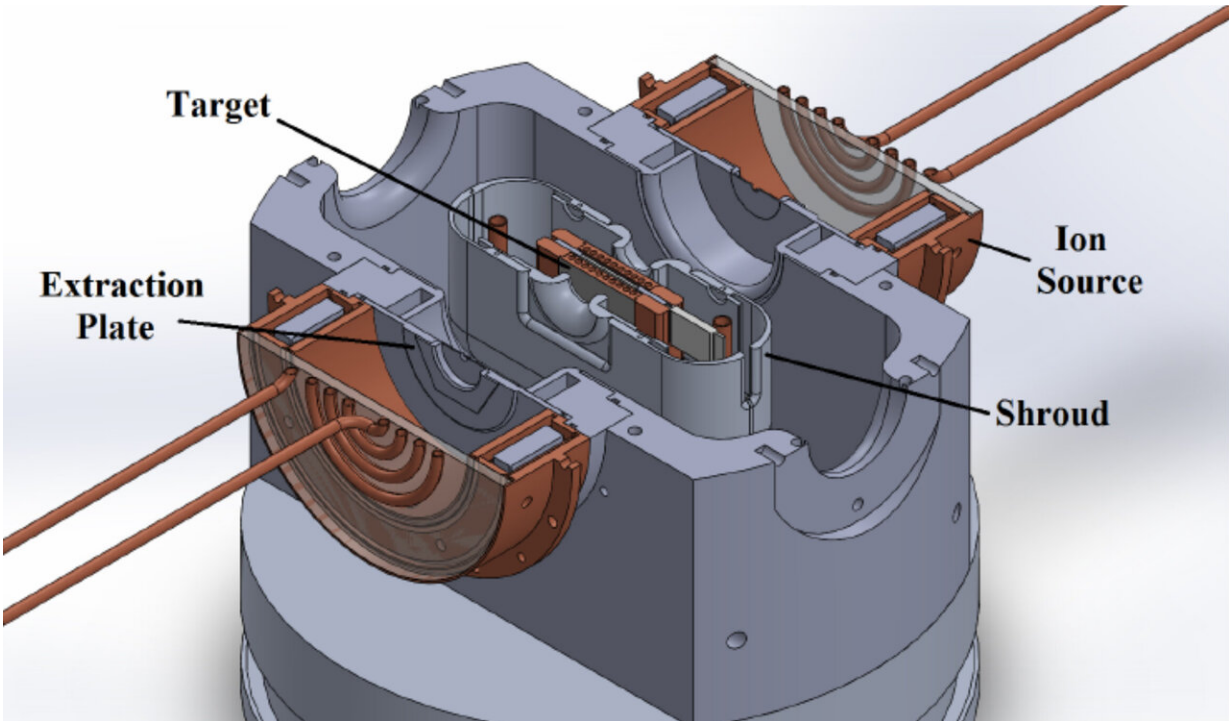

This cutaway of the high flux neutron generator shows the two chambers (bronze) where the deuterium is heated to 50,000 degrees Celsius, creating a plasma of ionized deuterium. A 100,000-volt charge at the extraction plate accelerates the ions toward the target, which contains more deuterium atoms. When two deuterium atoms fuse, they produce a neutron, which irradiates a sample placed nearby. The shroud prevents excessive heating from backstreaming electrons. Credit: Karl van Bibber, UC Berkeley

The long road to desktop fusion

Renne has been searching for better ways to irradiate rock samples for decades and heard about one possible method from the late UC Berkeley nuclear engineering professor Stanley Prussin, who died in 2015. The technique involves the fusion of two deuterium atoms, which are isotopes of hydrogen, to produce helium-3 and one neutron. These neutrons have an energy—about 2.5 million electron volts—that is ideal

for irradiating rocks to conduct argon-argon dating, one of the most precise methods in use today.

Argon-argon dating relies on the fact that about one in every 1,000 potassium atoms in rock is the radioactive isotope potassium-40, which decays to argon-40 with a half-life of more than a billion years. Using neutrons, scientists convert some of the stable potassium, potassium-39, to argon-39, then measure the ratio of Ar-40 to Ar-39 in the sample to calculate its age.

Rock samples must now be irradiated at nuclear reactors, but reactors produce very energetic neutrons that can knock argon atoms out of the sample—a particular problem for rocks with microscopic grains—and also produce unwanted radioactive elements. Both effects make age calculation more difficult.

The HFNG avoids both of these problems, because the neutrons are one-tenth the energy of those from a nuclear reactor and have a narrower range of energies, while still maintaining a high flux of neutrons.

"Eliminating the recoil issue, plus reduction of interfering reactions, is huge," Renne said. "But the radiological aspects are also improved."

"The beauty of this thing, we realized, is that you don't have this thing spewing neutrons everywhere and creating a radiological issue," added van Bibber, who is the Shankar Sastry Chair of Leadership and Innovation. "You're actually having a modest number of neutrons, but by getting the target close to the point source—the thing that matters—the neutron flux at the sample is very high."

The first device to create neutrons via deuterium-deuterium (D-D) fusion was designed 10 years ago by Renne's team, which included plasma physicist Ka-Ngo Leung, formerly of Lawrence Berkeley

National Laboratory (Berkeley Lab). But their prototype languished until van Bibber took an interest in 2012, shortly after his appointment as chair of UC Berkeley's Department of Nuclear Engineering. To house the fusion generator, van Bibber took over a concrete vault formerly used for experiments conducted with the campus's nuclear reactor, which used to sit under what is now Soda Hall—though it sits in a large underground room that is part of the basement of Etcheverry Hall—until the reactor closed in 1987 and was removed.

The generator employs about 100,000 volts to accelerate ionized deuterium atoms toward a metal cathode made of titanium. The deuterium accumulates on the cathode in a thin layer that then serves as a target for other incoming ions. When colliding deuterons fuse, a neutron is produced in a broad beam that irradiates the sample located about a third of an inch away.



Graduate students Mauricio Ayllon Unzueta (left) and Jonathan Morrell adjust the high flux neutron generator in an underground vault at UC Berkeley. The aluminum vacuum chamber contains the deuterium plasma and the cathode target where the neutrons are generated via fusion. Credit: UC Berkeley photo by Irene Yi

Over the years, van Bibber enlisted many undergraduates, graduate students and postdoctoral fellows to help make the neutron generator a reality. One of them, transfer student Max Wallace, a rising senior interested in nuclear forensics, was amazed at the access he had to such a machine.

"It's rare to be able to work with radioisotopes as an undergraduate," said the former software engineer. "I learned to do so much late at night, wearing gloves and goggles to measure the radiation, taking samples, doing safety checks and running the software. Really, I'd learn something in my nuclear physics class and then come down here to work on a direct application of it."

For Mauricio Ayllon Unzueta, a fourth-year graduate student in nuclear engineering, the experience he obtained in helping to perfect the neutron generator led directly to a new project at Berkeley Lab: designing a variant of the HFNG that could be taken into the field to do neutron activation of soils to measure carbon content—a key piece of information if society hopes to sequester carbon in soils to mitigate climate change.

"Through three generations of graduate students, we turned it from something which barely worked into a high performing neutron

generator," van Bibber said.

Daniel Rutte, a UC Berkeley postdoctoral researcher in geology working with Renne and BGC lab manager Tim Becker, played a critical role in designing and conducting the first dating experiment, according to Renne.

"Daniel was literally the key player in demonstrating that this would work for Ar-Ar geochronology," he said.

Rutte's goal is to develop new methods and instruments to better understand Earth processes, in particular the deformation of the Earth's crust, which occurs by slow creep or rapid rupture resulting in earthquakes.

"To understand long-term crustal deformation, I date old ruptures preserved in the rock record," Rutte said. "The neutron generator will aid progress in this field by expanding the range of materials we can date."

With ongoing student help, van Bibber and Renne expect to be able to make the neutron generator more compact and to produce a more intense spray of neutrons, making it more broadly useful for geochronology, as well as for other specialized uses. Researchers at UC Berkeley's Space Sciences Laboratory have already shown interest in using these neutrons to test electronic hardware to determine how it will survive in the radioactive environment of space. Higher energy neutrons could be used for neutron radiography, which can complement X-ray radiography in imaging the interior of dense objects, like metals.

"The purpose all along had been to test Paul's dream of whether we could use a very compact, low-voltage device to do neutron irradiation," van Bibber said. "We've now shown that any university can have a [neutron](#) source for doing the argon-argon dating technique."

More information: "Boutique neutrons advance $^{40}\text{Ar}/^{39}\text{Ar}$ geochronology" *Science Advances* (2019).

advances.sciencemag.org/content/5/9/eaaw5526

Provided by University of California - Berkeley

Citation: Students make neutrons dance beneath UC Berkeley campus (2019, September 11)
retrieved 19 April 2024 from

<https://phys.org/news/2019-09-students-neutrons-beneath-uc-berkeley.html>

This document is subject to copyright. Apart from any fair dealing for the purpose of private study or research, no part may be reproduced without the written permission. The content is provided for information purposes only.