

# Conceptual design ready for PLATO telescope simulator

August 15 2019

---

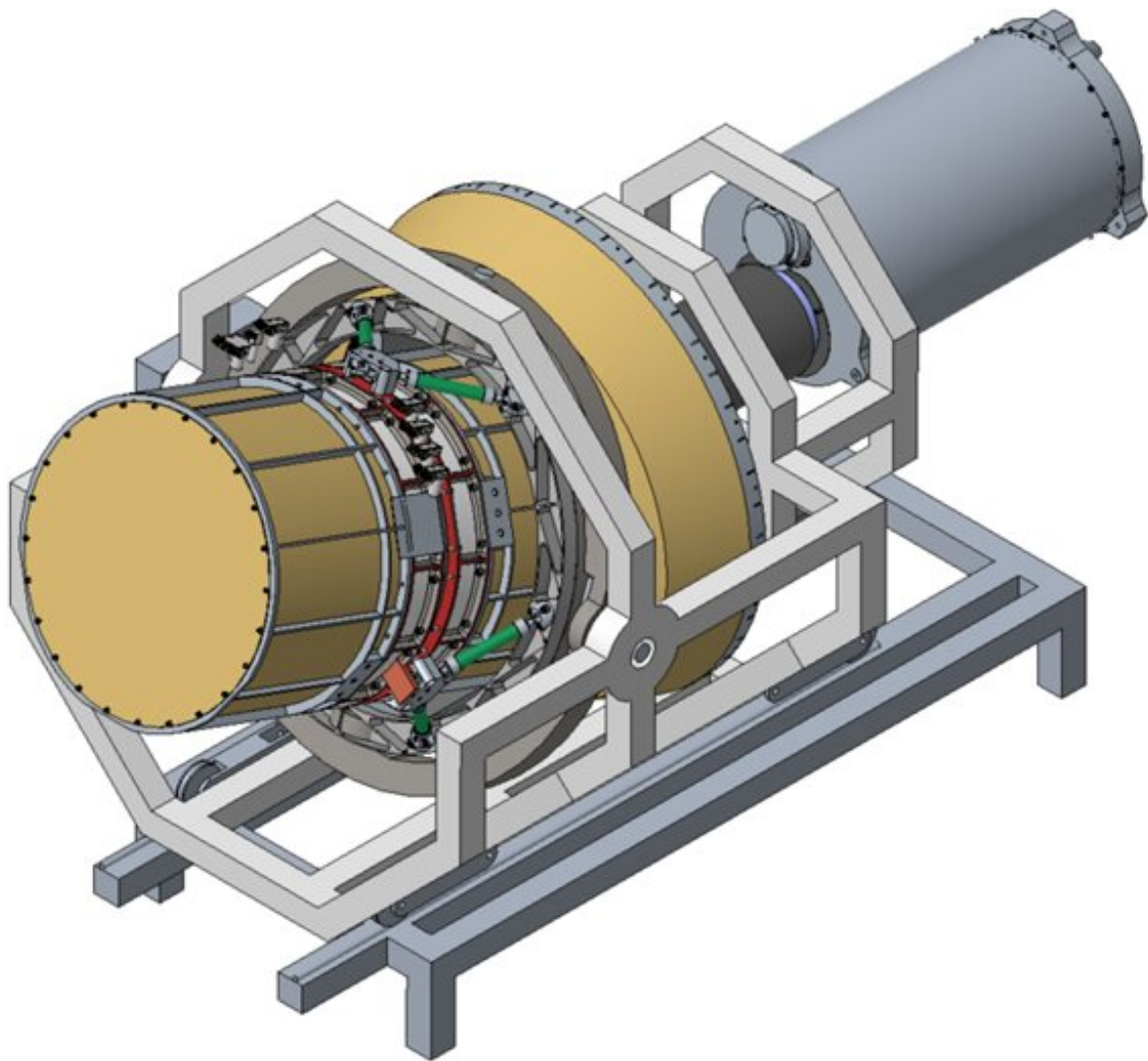

Conceptual design of the space simulator for cameras on PLATO Credit: SRON  
Netherlands Institute for Space Research

SRON Netherlands Institute for Space Research designs and builds a space simulator to test and calibrate eight out of twenty-six cameras for ESA's next exoplanet hunter telescope, PLATO. The conceptual design is now complete. PLATO will be able to spot smaller planets in larger orbits than its predecessors. This could lead to the discovery of Earth-sized planets within the habitable zone. The telescope is even sensitive enough to measure characteristics of potential atmospheres around these planets.

Over the last decade, astronomers have been discovering more and more exoplanets. They have now reached the conclusion that there are at least as many [planets](#) in our Universe as there are stars. In our Milky Way alone, there should be over a hundred billion planets. Currently, more than four thousand planets have been confirmed.

### **Continuous monitoring**

The most effective method for discovering planets is to check for tiny variations in a star's brightness. This reveals a planet passing in front and blocking a bit of starlight. ESA's PLATO space telescope will use that same method, with the special feature that it monitors single stars uninterrupted for years in a row. This will allow astronomers to discover smaller planets with longer transit periods than previous exoplanet hunters. Here we enter the domain of Earth-sized planets within the habitable zone around a host star. On top of that its sensitivity will allow scientists to extract characteristics of potential atmospheres around these planets such as cloud cover and to create a catalogue for follow-up exoplanet atmospheric research.



Artist impression PLATO space telescope Credit: DLR

## Simulator

SRON will design and build a [space simulator](#) to test and calibrate eight out of PLATO's twenty-six cameras. SRON scientists have now finished their [conceptual design](#). They will use the simulator to determine the size and shape of the so-called point spread function. Instead of a point of light, telescopes see a star in the form of a disk that is brightest in the center and steeply fades towards the edge. This is due to minute imperfections in the telescope optics. In SRON's design, optics simulate a star in the sky while a radiation shield mimics the extremely low temperatures of deep space. The latter is part of another just as important test to verify the correct behavior of the [camera](#) in [space](#). In the end, the simulator determines if the cameras meet PLATO requirements and it provides important calibration parameters.

## Cleanliness

Because the actual flight cameras will be tested, the simulator is designed in such a way that it provides maximum safety. A single speck of dust could lead to reduced sensitivity and false detections. "PLATO has a stringent requirement for contamination, even compared to other spacecraft, so we need to test the cameras in extremely clean conditions," says Lorenza Ferrari, SRON's project leader for PLATO. "We can only have 70 parts per million of particulates on the surface. That is 0.007%. With the naked eye you can't see under 300 parts per million." SRON will start assembling the components for the actual [simulator](#) in August 2020. It should be ready by November 2020. PLATO will be launched in 2026.

Provided by SRON Netherlands Institute for Space Research

Citation: Conceptual design ready for PLATO telescope simulator (2019, August 15) retrieved 3 May 2024 from <https://phys.org/news/2019-08-ready-plato-telescope-simulator.html>

<p>This document is subject to copyright. Apart from any fair dealing for the purpose of private study or research, no part may be reproduced without the written permission. The content is provided for information purposes only.</p>
--