

Chinese team runs cold atomic clock in space for 15 months

July 26 2018, by Bob Yirka

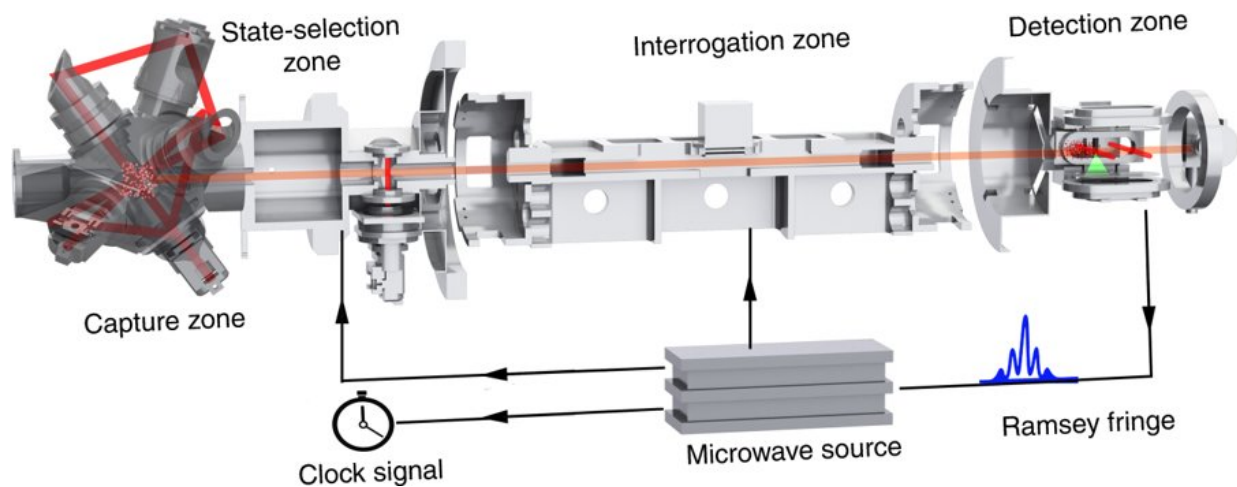

In-orbit operation of an atomic clock based on laser-cooled ^{87}Rb atoms. Principle and structure of the space cold atom clock (CAC). The capture zone is a magneto-optical trap (MOT) with a folded beam design. The ring interrogation cavity is used for the microwave field to interrogate the cold atoms. In the detection zone, cold atoms in both hyperfine states are detected. The clock signal is obtained by feeding the error signal to the frequency of microwave source. Credit: *Nature Communications* (2018). DOI: 10.1038/s41467-018-05219-z

A team of researchers at the Chinese Academy of Sciences has successfully operated a cold atomic clock in space for a period of 15 months. In their paper published in the journal *Nature Communications*, the group describes how they succeeded in achieving the difficult task.

Cold atomic clocks keep time by measuring atomic oscillations in [free fall](#) (so no interference occurs). They are chilled, as their name implies, to near [absolute zero](#) using lasers, which makes them more precise. It would be convenient for researchers to have a cold atomic [clock](#) run in [space](#)—that would allow for measuring time more precisely for such things as GPS applications. But space presents challenges that are not present on Earth, including the size and weight of the apparatus—both are at a premium on spacecraft. There is also the matter of shielding the clock from [cosmic radiation](#). Such roadblocks have prevented the use of these clocks in space, until now.

In this new effort, the researchers report that they have successfully run a cold atomic clock on board an Earth-orbiting vehicle—the Tiangong-2 Chinese space station. They report further that they ran the clock for 15 months, and during that time, they achieved a frequency stability of $3.0 \times 10^{-13} \tau^{-1/2}$.

The clock used by the team was encased in three layers of mu-metal and was held at a pressure of 10^{-12} atmospheres. The servo-motors used to stabilize the pressure were also shielded to prevent interference from their magnetic fields. Inside of the device was a trap isolating 50 million rubidium-87 atoms held steady by microwaves and laser pulses. Measuring was done using interferometry.

The researchers suggest similar space-based clocks could be used for metrology as well as for testing principles of General Relativity and other fundamental physics constants.

More information: Liang Liu et al. In-orbit operation of an atomic clock based on laser-cooled 87Rb atoms, *Nature Communications* (2018). [DOI: 10.1038/s41467-018-05219-z](https://doi.org/10.1038/s41467-018-05219-z)

Abstract

Atomic clocks based on laser-cooled atoms are widely used as primary frequency standards. Deploying such cold atom clocks (CACs) in space is foreseen to have many applications. Here we present tests of a CAC operating in space. In orbital microgravity, the atoms are cooled, trapped, launched, and finally detected after being interrogated by a microwave field using the Ramsey method. Perturbing influences from the orbital environment on the atoms such as varying magnetic fields and the passage of the spacecraft through Earth's radiation belt are also controlled and mitigated. With appropriate parameters settings, closed-loop locking of the CAC is realized in orbit and an estimated short-term frequency stability close to $3.0 \times 10^{-13} \tau^{-1/2}$ has been attained. The demonstration of the long-term operation of cold atom clock in orbit opens possibility on the applications of space-based cold atom sensors.

© 2018 Phys.org

Citation: Chinese team runs cold atomic clock in space for 15 months (2018, July 26) retrieved 25 April 2024 from <https://phys.org/news/2018-07-chinese-team-cold-atomic-clock.html>

This document is subject to copyright. Apart from any fair dealing for the purpose of private study or research, no part may be reproduced without the written permission. The content is provided for information purposes only.