

Compliant materials with a strong impact

October 29 2013



The recent Empa spin-off Monolitix AG specialises in compliant mechanisms. These are frictionless and wear-free and are also lighter, more hygienic and cheaper than conventional joint mechanisms. They have an enormous range of potential applications in the most diverse fields. The new company's young entrepreneurs are now setting about breaking into the market with their first products.

We are surrounded by objects with joints from morning till night. "We

come across them in a thousand different forms", explains Flavio Campanile, aeronautical engineer and Chairman of the Board of Directors at the Empa spin-off Monolitix. "Without joints, everything would be rigid: you would not be able to steer a car and the brakes on bicycles would not work." The "trick" is that rather than using conventional bearings and joints to create the required movement for a mechanism, these so-called solid-state mechanisms deliberately dispense with these types of elements. Instead, the material is deformed in a controlled and reversible way. As a figurative example, instead of a pair of pliers made from several parts, as representative of the traditional joint principle, Campanile highlights a pair of tweezers made from a single, elastically deformable component.

Monolithic systems with many advantages

"The advantages of monolithic systems are obvious" explains Campanile: joint-free mechanisms are frictionless and wear-free and therefore also maintenance-free. This can drastically reduce the running costs of machines and instruments. In areas where high standards of hygiene are required, such as in medical devices or in the food industry, they are advantageous because they are easier to clean and sterilise. In addition, with solid-state mechanisms, assembly costs can be reduced dramatically or even avoided altogether. This leads to much cheaper production processes.

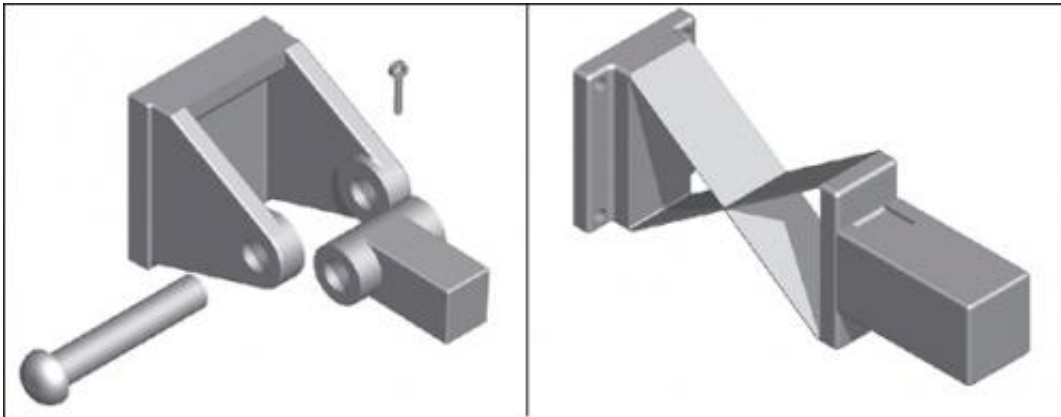

A conventional joint construction (left) has a very simple design. A monolithic solution (right) has a more complex design, but has many advantages in operation.

And finally, compliant mechanisms can also perform functions that would be inconceivable with conventional systems: for example, aircraft wings which constantly change their geometry - like those found in nature - and optimise their use of the aerodynamic forces. Another possibility is rear spoilers for Formula 1 racing cars which generate more down force with the same air resistance, thus enabling the car to travel faster through corners. Compliant concepts are also extremely well-suited to rotor blades on wind turbines that are difficult to access or for anti-friction and friction bearings in [solar power plants](#), which are subjected to mud, sand or dust and have to function under extreme conditions.

The business idea began to take shape when Campanile's doctoral students at the Federal Institute of Technology (ETH) Zurich, René Jähne and Alexander Hasse, began working in this field. The first prototypes for medical technology were created in the course of their dissertations. This is how the ideas came to life. For many years, the team of three carried out their research at the Empa laboratory

"Mechanics for Modelling and Simulation", during which time they developed techniques for analysing flexible elements and their deformation as well as algorithms for shape optimisation. Their results were then incorporated into software modules, databases and patents. The time to establish their own company came in 2010.

Gripping systems from the catalogue and innovative ideas from the custom manufacturing team



A range of robotic grippers from Monolitix is already available to mechanical engineers. They are extremely light, free of play and frictionless.

Even before they joined glaTec, Empa's business start-up centre in Dübendorf, they acquired their first customer: baked-goods manufacturer HUG uses their robotic grippers to take small pastry cases

carefully, quickly and hygienically off the production line and put them into their packaging. The task for Campanile and his colleagues is now to inspire new customers with their many ideas and to persuade them to develop new products together. The Head of Product Development at Monolitix, René Jähne, explains: "As a small company, it would be too expensive for us to develop and market complex products for a specific market single-handedly." The company does offer a small, but refined range of gripping systems in its catalogue. However, an approach that he believes will be far more successful is to actively approach manufacturers of machine components, tools and instruments. According to Jähne, "In this way, with every project, we become better acquainted with the needs of individual partners and their markets." During the discussions, clients in return gain an insight into the engineering work carried out at Monolitix. It is quickly becoming clear that the design for a compliant system can ultimately only be created with a multidisciplinary approach and a lot of expertise.

Demand for the new technology is strong, as the company's founders are proud to note, also referring to the fact that Monolitix is already financially independent. This is quite unusual for such a young company. According to the business plan, Monolitix should grow into an SME with around 40 employees within the next five years. If things continue to develop as ra

Provided by Swiss Federal Laboratories for Materials Science and Technology

Citation: Compliant materials with a strong impact (2013, October 29) retrieved 12 July 2024 from <https://phys.org/news/2013-10-compliant-materials-strong-impact.html>

This document is subject to copyright. Apart from any fair dealing for the purpose of private study or research, no part may be reproduced without the written permission. The content is

provided for information purposes only.